

A phylogeny analysis on six mullet species (Teleosti: Mugillidae) using PCR-sequencing method

Nematzadeh M.^{1*}; Rezvani S.²; Khalesi M.K.¹; Laloei F.³; Fahim A.⁴

Received: September 2011

Accepted: September 2012

Abstract

In this study, genetic differences and phylogenetic relationships among six Mugillidae species (*Mugil cephalus*, *M. capito*, *Liza subviridis*, *L. saliens*, *L. aurata*, *Valamugil buchanani*) were determined using PCR-sequencing. *M. cephalus*, *L. subviridis*, and *V. buchanani* from the Persian Gulf and Oman Sea, and *L. aurata* and *L. saliens* from the Caspian Sea were collected. Samples of an imported, Egyptian species *M. capito* were obtained from the Gomi-shan Research Center in Gorgan. Total DNA from the samples were extracted according to phenol-chloroform procedure. The extracted total DNAs were amplified using polymerase chain reaction (PCR) and then sequenced. The number of bases in the mitochondrial 16s rRNA genome used in this study approximated 600 base pairs. The size of the bands was identical in all the studied species and no heteroplasma was observed. In addition, the numbers of variable, preserved, and Pi sites were about 114/624, 488/624, and 110/624, respectively. Analysis of the sequences showed great differences between *Mugil* species and the other studied species. The phylogenetic tree obtained through Neighbor-Joining method revealed that *L. saliens* and *L. aurata* were in the same branch while *L. subviridis* was in a separate branch. In contrast, Maximum Parsimony tree located *L. subviridis* and *L. aurata* in a single branch and assigned *L. saliens* to a distinct branch. This result brings in the question of monophyletic origin of the genus *Liza*.

Keywords: Sequencing, Mugillidae, Phylogeny, PCR, Persian Gulf, Oman Sea, Caspian Sea

1- Sari Agricultural Sciences and Natural Resources University; Sari, Mazandaran, Iran.

2- Iranian Fisheries Research Organization, Tehran, Iran.

3- Caspian Sea Ecological Research Institute, Mazandarn, Iran.

4- Faculty of Basic Sciences, University of Tehran, Iran.

*Corresponding author's email: nematzadeh.ma@yahoo.com

Introduction

The grey mullet (Mugilidae) are distributed throughout coastal and brackish waters in the tropical and subtropical regions of the world (Papasotiropoulos et al., 2007). In Iran, mullet species occur at all three basins of northern, southern, and inland waters. The existing mullet species in the Persian Gulf including *Mugil cephalus*, *Liza subviridis*, and *Valamugil buchanani* have also migrated the southern rivers of Iran (Ghelichi et al., 2003). During the years 1930 – 1934, scientists from the former Soviet Union introduced different mullet species from the Black Sea including grey mullet (*M. cephalus*), leaping grey mullet (*L. saliens*), and golden mullet (*L. auratus*). The introduction of the two latter species was successful, which are currently of high economic importance (Fazli and Ghaninejad, 2003).

This family was previously classified in the order Perciformes (Nelson, 1994) but was later assigned to a new order, the Mugiliformes. In the most recent classification (Nelson, 2006), the Mugilidae consists of 17 genera and 72 species, the majority of which located in the two genera of *Mugil* and *Liza*. Despite these important classifications (Nelson, 1994; Thomson, 1997), the systematic status of some genera and species of this family is still uncertain (Rossi et al., 1998, Semina et al., 2007). Although several studies clarified the taxonomic status of Mugilidae (Schultz, 1946; Trewaves and Ingham, 1972; Thomson, 1981, 1997; Harrison and Howes, 1991) they were, however, based

on traditional analysis of morphological traits, and the obtained results were in some cases controversial. In fact, most members of this family are very similar to each other making it a limiting factor for addressing the questions concerning phylogenetic relationships (particularly at intraspecies level) of mullets (Stiassny, 1993; Papasotiropoulos et al., 2007; Liu et al., 2010).

The phylogenetic relationships among mullet species have recently been determined using characteristics other than morphological traits and advanced techniques have been developed based on molecular genetics in order to identify fish species and to study DNAs from diverse populations by the use of both mitochondrial (mtDNA) and nuclear (nDNA) genomes (Avis, 1991; Papasotiropoulos et al., 2007; Semina et al., 2007). The mtDNA has turned out to be an efficient genetic marker for the study of molecular systematics in population genetics and of phylogenetic relationships because of maternal inheritance, no occurrences of recombination, and lesser mean rate of exchange and replacement in mtDNA nucleotides than those in nDNA (Asensio, 2007; Ghorashi et al., 2008).

In the present study, therefore, the phylogenetic relationships among highly economic mullet species from the Caspian Sea (*Liza aurata* and *L. saliens*), the Persian Gulf and Oman Sea (*Mugil cephalus*, *L. subviridis*, and *Valamugil buchanani*) and also a newly imported, Egyptian species (*M. capito*) were verified using partial

mtDNA sequencing. The objective was to make an attempt for the determination of taxonomy of the above mullet species.

Materials and methods

DNA sampling and extraction

Two to seven samples (e.g. Papatziropoulos et al., 2007) of each mullet species were collected from the Caspian Sea (*L. aurata* and *L. saliens*), the Persian Gulf (*Liza subviridis* and *Valamugil buchana-ni*), the Oman Sea (*M. cephalus*), and an imported species (*M. capito*) from a local research institute (Gomishan, Iran). Fin tissues were obtained from the fish and preserved in 1500-L tubes containing absolute ethanol. These samples were then transferred to a molecular laboratory located at the Caspian Sea Ecology Research Center, Sari, Iran, where the fish's DNA was extracted using phenol-chloroform method (Fevolden and Pogson, 1997). Thereafter, both the quality and quantity of the extracted DNA was assessed by agarose gel (1%) electrophoresis according to Rezvani (1997). For the multiplication of 16s rRNA genome, the following primer pair was used:

16SARL(5-CGCCTGTTTATCAAAAACAT-3) and 16SBRH (5-CCGGTCTGAACTCAGATCACGT-3)

by the use of PCR. To do this (corbett research model), different materials including 0.4 µl of dNTP (10 mmol), 0.4 µl of the enzyme Tag DNA polymerase (unit 2),

1.6 µl of MgCl₂ (50 mmol), 1.0-5.0 µl of the extracted DNA (50- 100 nanogram), 5.0 µl buffer (10×) PCR, 2.0 µl of each primer, and adequate distilled water were mixed up to a volume of 50 µl in a 200- µl micro-tube. The containing tube was placed in a thermal cycler unit for which the time and temperature settings were as below:

Stage 1: denaturation at 94 °C for 3 min. (one cycle); stage 2: denaturation at 94 °C for 60 sec., annealing at 60 °C for 60 sec., extension: at 72 °C for 90 sec. (30 cycles); stage 3: final extension at 72 °C for 3 min. (one cycle).

The PCR product was purified using a commercial kit (QIA quick PCR purification kit, Qiagen) according to the provided protocol. Afterwards, the purified PCR samples were sent to a company in France for DNA sequencing.

Molecular Analysis

All the obtained sequences were verified as being derived from mullet's DNA using the GenBank Blast algorithm. Bioedit software version 7.0.9 was used for editing the sequences. They were then all aligned using Clustal W (Thompson et al., 1994). Finally, the sequences were scanned by eye for conserved, variable and parsimony informative sites. The phylogenetic analysis used were Maximum Parsimony, Neighbor-Joining and Maximum-Evolution in MEGA4 software (Tamura et al., 2006) and confidence in the nodes was evaluated by 10000 bootstrap pseudoreplicates (Felsenstein, 1985). Divergence time

was estimated using Tajima's Test (Tajima, 1993) as well as the average net distance between groups (Tajima and Nei, 1984) besides molecular clock approximation for mtDNA of 2% nucleotide sequence divergence per million years (Brown et al., 1979). For the construction of the phylogenetic trees, sequences of *Xiphias gladius* were used as outgroups to root the trees.

Results

The number of bases in the mitochondrial 16s rRNA genome used in this study approximated 600 base pairs. The size of the bands was identical in all the studied species and no heteroplasma was observed.

The numbers of variable sites were about 114/624, preserved sites 488/624, and Pi sites 110/624. Analysis of this genome showed the highest genetic divergence between *Mugil cephalus* and the other species with the lowest and greatest divergence between *V. buchanani* and *M. cephalus*; *Liza auratus* & *L. saliens* and *M. cephalus* & *M. capito*, respectively. According to Table 1, the highest and lowest genetic distances were detected between *V. buchanani* and *M. cephalus*; *Liza auratus* & *L. saliens* and *M. cephalus* & *M. capito*, respectively. Table 1 also reveals that *M. cephalus* has the greatest genetic distance with the other species in the present study. In addition, the phylogenetic tree depicted in the current study using Maximum Parsimony and Neighbor-Joining methods represents *M. cephalus* as having the farthest genetic distance with the other mullet

species and the respective branch is also longer than other branches of the tree. The other studied mullet species all appear in a single branch. *V. buchanani* forms a sister group with the *Liza* species. The difference between the two trees is that in the Neighbor-Joining tree, *L. subviridis* is located in one branch, and *L. aurata* and *L. saliens* are situated in another branch close to each other; the Maximum Parsimony tree, on the other hand, places *L. saliens* in one branch, and *L. subviridis* and *L. aurata* in a different branch next to each other (Figs. 1 and 2).

N – J :

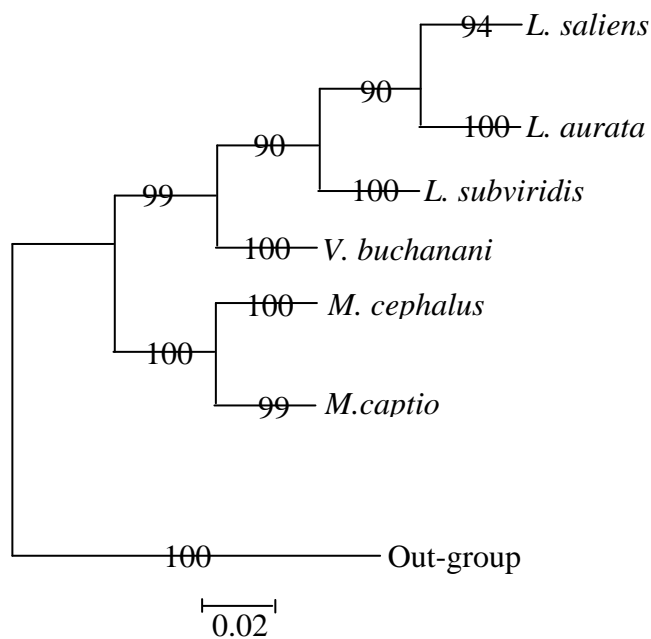

Figure 1: Neighbor-Joining (N-J) tree drawn for six mullet species in this study. The numbers show confidence level of the depicted branch.

MP:

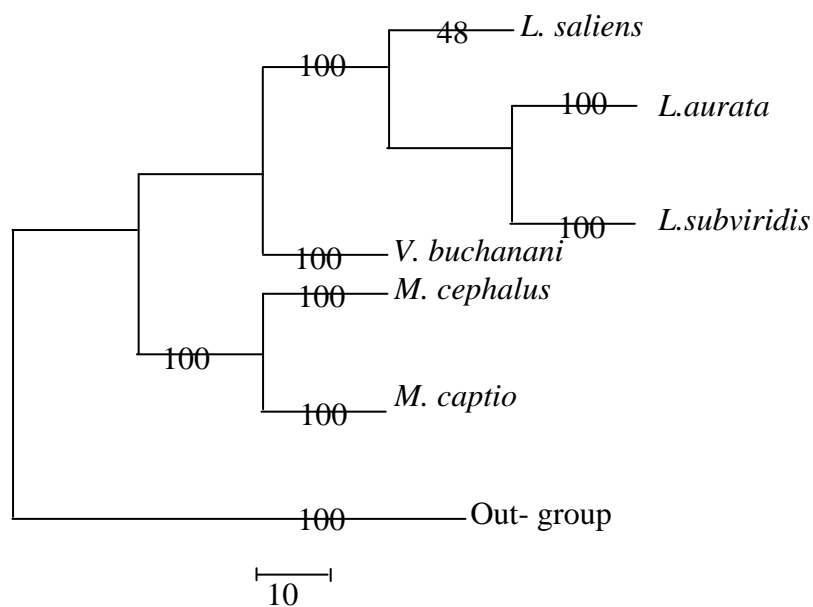

Figure 2: Maximum Parsimony tree drawn for six mullet species in this study. The numbers show confidence level of the depicted branch.

Table 1: Total genetic distance between the six studied mullet species

	1	2	3	4	5	6
1. <i>Mugil cephalus</i>	-	-	-	-	-	-
2. <i>Mugil capito</i>	0.015	-	-	-	-	-
3. <i>Liza saliens</i>	0.130	0.128	-	-	-	-
4. <i>Valamugil buchanani</i>	0.149	0.142	0.057	-	-	-
5. <i>Liza subviridis</i>	0.130	0.128	0.019	0.074	-	-
6. <i>Liza aurata</i>	0.142	0.139	0.015	0.067	0.027	-

Discussion

The current study examined the phylogenetic relationships among six mullet species using the mitochondrial 16s rRNA genome. The highest genetic divergence detected for *M. cephalus* compared with the other studied mullet species. This could be a result of faster substitution rate observed in this species, which could be explained as a combined effect of nucleotide bias and saturation of signal (Martin, 1995). This observation is in agreement with Papisotiropoulos (2001, 2002, 2007), who applied PCR-RFLP, and allozyme, and sequenced three mtDNA genome (COI, 12s rRNA, 16s rRNA). This finding is also in line with other similar studies (Caldara et al., 1996; Murgia et al., 2002; Rossi et al., 2004; Turan et al., 2005; Fraga et al., 2007; Liu et al., 2010), which was confirmed previously through chromosome studies as well (Cataudella et al., 1974; Rossi et al., 1997; Gornung et al., 2001). Cataudella et al. (1974) stated that the karyotype of *M. cephalus* was similar to that described by Ohno (1974), which

was known as the ancestor of all teleosts. The karyoevolutive pattern proposed by the above-mentioned investigators suggests that the karyotypes of species belonging to the genera *Liza* and *Chelon* might have derived through a translocation event from an ancestral karyotype similar to that found in *M. cephalus*. Besides, recent findings of Liu et al. (2010) show a great genetic divergence between the lineage of *M. cephalus* occurring in the northern and southern China Sea. Such a genetic divergence may not be detected morphologically owing to the development of fish organs making them (*M. cephalus* from the north and south coasts of the China Sea) all with similar appearances.

The large genetic divergence between *M. cephalus* and other mullet species is in contrast with their high morphological similarity, although such contradictions are often present in literature (Patterson et al., 1993). The lack of parallel evolution between morphology and some portions of DNA has already been reported for other groups of fish (e.g. Meyer et al.,

1990) and might be explained by differences in the selective constraints operating on these two characters (Caldara et al., 1996). There are some ideas (e.g. Caldara et al., 1996; Smith et al., 2003; Rossi et al., 2004; Turan et al., 2005) on the need for a re-consideration in the systematic classification of mullet species. A Neighbor-Joining phylogenetic tree presented by Hillis and Bull (1993) located *M. cephalus* in a solely separate branch, a result reported by Caldara et al. (1996), Murgia et al. (2002), and Papatropoulos et al. (2001, 2002, 2007) as well. Results of Papatropoulos et al. (2007) on both N-J and Bayesian topologies agree that *M. cephalus* falls into a completely separate phylogenetic branch being a sister group to all other Mediterranean species studied. This is in agreement with their previous studies based on allozyme and PCR-RFLP data. Considering the high level of bootstrap in both trees obtained from Maximum Parsimony and Neighbor-Joining methods, this study also placed *M. cephalus* in a completely distinct branch supporting the idea of re-consideration in the taxonomy of mullet species.

In the Maximum Parsimony tree, *L. saliens* lied in a branch different from the other *Liza* species, whereas the Neighbor-Joining tree assigned *L. subviridis* to a branch dissimilar with *L. aurata* and *L. saliens*. Taking the two trees into account, these three species from the genus *Liza* did not place in a single branch. This result corresponds to Papatropoulos et al. (2007) but it disagrees with Papatropoulos et al. (2002). The latter study indicated

that three *Liza* species all located in a similar branch. The observed disparity may have arisen from differences in the methods used leading to a better result due to application of nucleotide sequencing as opposed to PCR-RFLP approach (Papatropoulos et al., 2007). It is noteworthy here that Rossi et al. (2004) conducted studies using 16s rRNA genome and achieved outcomes similar to the present study as well as those of Papatropoulos et al. (2007) concerning phylogenetic relationships of mullets. Rossi et al. (2004) noted that three *Liza* species (*L. saliens*, *L. aurata*, *L. ramada*) from the Mediterranean did not lie in one branch. Likewise, Harrison and Howes (1991) studied pharyngobranchial organ in mullet species and concluded that the *Liza* species did not locate in a single branch. The discrepancies in reported phylogenetic relationships among *Liza* species may be caused by differences in the applied genetic systems (mtDNA vs. allozyme), use of various mtDNA pieces, and/or sampling the studied mullet species from diverse geographic regions (Papatropoulos et al., 2007).

However, some dissimilarity is occasionally detected in the resultant phylogenetic relationships through molecular and morphological examinations. This is not extraordinary by any means because in the taxonomy science it is difficult to prove morphological differences and also it is not straightforward to decide on which morphological trait is more accurate for classification (Liu et al., 2010). As shown by Tortonese (1975), the importance of eyelid as a detectable trait is vague, and

Song (1982) found that the development of eyelid in *L. haematocheila* depended on the individual growth of samples of this species. Altogether, it seems necessary that more studies are performed regarding classification of mullets; especially classification of *Liza* genus.

Acknowledgments

The authors are grateful to the Iranian Fisheries Research Organization for financial support and laboratory facilities.

References

- Asensio, L. G., 2007.** PCR-based methods for fish and fishery products authentication. *Food Science & Technology journal*, 18: 558-568.
- Avis, J. C., Arnold, J., Ball, R. M., Bermingham, E., Lamb, T., Neigel, J. E., Reeb, C. A. and Saunders, S. C., 1987.** Intraspecific phylogeography: the mitochondrial bridge between population genetics and systematics. *Annual Review of Ecology, Evolution, and Systematics* 18: 489-522.
- Billington, N. and Hebert, P., 1991.** Mitochondrial DNA diversity in fishes and its implications for introductions. *Canadian Journal of Fisheries and Aquatic Sciences* 48: 80-94.
- Brown, W. M., George, J. R. M. and Wilson, A.C., 1979.** Rapid evolution of animal mitochondrial DNA. *Proc. Natl. Acad. Sci. USA.* 76: 1967-1971.
- Caldara, F., Bargelloni, L., Ostellari, L., Penzo, E., Colombo, L. and Patarnello, T., 1996.** Molecular phylogeny of grey mullets based on mitochondrial DNA sequence analysis: evidence of a differential rate of evolution at the intrafamily level. *Molecular Phylogenetics and Evolution* 6: 416-424.
- Cataudella, S., Civitelli, M.V. and Capanna, E., 1974.** Chromosome complements of the Mediterranean mullets (Pisces, Perciformes). *Caryologia* 27: 93-105.
- Erguden, D., Gurlek, M., Yaglioglu, D. and Turan, C., 2010.** Genetic identification and taxonomic relationship of Mediterranean Mugilid species based on Mitochondrial 16s rDNA sequence data. *Journal of Animal and Veterinary Advances* 9(2): 336-341.
- Fazli, H. and Ghaninejad, D., 2004.** A study on catch and some biological aspects of mullets in the southern basin of the Caspian Sea. *Iranian Journal of Fisheries Sciences* 97-116.
- Felsenstein, J., 1985.** Confidence limited on phylogenies: An approach using the bootstrap. *Evolution* 39: 783-791.
- Fevolden, S. E. and Pogson, G. H., 1997.** Genetic divergence at the synaptophysin locus among Norwegian coastal and north-east Arctic population of Atlantic cod. *Journal Fish Biology* 51: 895-908.
- Fraga, E., Schneider, H., Nirchio, M., Santa-Brigida, E., Rodrigues-**

- Filho, L.F. and Sampaio, I., 2007.** Molecular phylogenetic analyses of mullets (Mugilidae, Mugiliformes) based on two mitochondrial genes. *Journal of Applied Ichthyology* 23: 598–604.
- Ghelichi, A., Oryan, S., Ahmadi, M., Kazemi, R. and Hallajian, A., 2003.** Histology of different stages of ovary development in the grey mullet and Gomishan shrimp. *Journal of Agricultural Sciences* www.oxinads.com.
- Ghorashi, S. A., Fatemi, S. M., Amini, F., Houshmand, M., Salehitabar, R. and Hazaie, K., 2008.** Phylogenetic analysis of anemone fishes of the Persian Gulf using mtDNA sequencing. *African Journal of Biotechnology* 7 (12): 2074-2080.
- Gonzales-Villasenor, L. I. and Powers, D. A., 1990.** Mitochondrial restriction-site polymorphisms in the teleost *Fundulus heteroclitus* support secondary integration. *Evolution* 44:27-37.
- Gornung, E., Cordisco, C. A., Rossi, A. R., De Innocentilis, S., Crosetti, D. and Sola, L., 2001.** Chromosomal evolution in mugilids: karyotype characterization of *Liza saliens* and comparative localization of major and minor ribosomal genes in the six Mediterranean grey mullets. *Marine Biology* 139:55-60.
- Harrison, I. J. and Howes, G. J., 1991.** The pharyngobranchial organ of mugilid fishes: its structure, variability, ontogeny, possible function and taxonomic utility. *Bulletin of the Natural History Museum (Zool)* 57: 111-132.
- Hillis, D. M. and Bull, J. J., 1993.** An empirical test of bootstrapping as a method for assessing confidence in phylogenetic analysis. *Systematic biology* 42: 182-192.
- Knowlton, N., Weigt, L. A., Solorzan, L. A., Mills, D. K. and Bermingham, E., 1993.** Divergence in proteins, mitochondrial DNA, and reproductive compatibility across the Isthmus of Panama. *Science* 260: 1629–1632.
- Liu, J. Y., brown, C. L. and Yong, T. B., 2010.** Phylogenetic relationships of mullets (Mugilidae) in China Seas based on partial sequences of two mitochondrial genes. *Biochemical Systematics and Ecology* 38: 647-655.
- Martin, A. W., 1995.** Mitochondrial DNA sequence evolution in sharks: rates, patterns, and phylogenetic inferences. *Molecular Biology and Evolution* 12: 1114-1123.
- Meyer, A., Kocher, T. D., Basasibwaki, P. and Wilson, A. C., 1990.** Monophyletic origin of Lake Victoria cichlid fishes suggested by mitochondrial DNA sequences. *Nature* 347: 550-553.
- Moritz, C., Dowling, T. E. and Brown, W. M., 1987.** Evolution of animal mitochondrial DNA: relevance for population biology and systematics. *Annual Review of Ecology, Evolution, and Systematics* 18: 269-292.

- Murgia, R., Tola, G., Archer, S. N., Vallerga, S. and Hirano, J., 2002.** Genetic identification of grey mullet species (Mugilidae) by analysis of mitochondrial DNA sequence: application to identify the origin of processed ovary products (bottarga). *Marine Biotechnology* 4, 119–126.
- Omland, K. E., Tarr, C. L., Boarman, W. I., Marzluff, J. M. and Fleischer, R. C., 2000.** Cryptic genetic variation and paraphyly in ravens. *Proc. R. Soc. Lond. B. Biol. Sci.* 267, 2475–2482.
- Papasotiropoulos, V., Klossa-Kilia, E., Kiliyas, G. and Alahiotis, S., 2001.** Genetic divergence and phylogenetic relationships in grey mullets (Teleostei: Mugilidae) using allozyme data. *Biochemical genetics* 39, 155–168.
- Papasotiropoulos, V., Klossa-Kilia, E., Kiliyas, G. and Alahiotis, S., 2002.** Genetic divergence and phylogenetic relationships in grey mullets (Teleostei: Mugilidae) based on PCR–RFLP analysis of mtDNA segments. *Biochemical Genetics* 40, 71–86.
- Papasotiropoulos, V., Klossa-Kilia, E., Alahiotis, S. N. and Kiliyas, G., 2007.** Molecular phylogeny of grey mullet (Teleostei: Mugilidae) in Greece: evidence from sequence analysis of mtDNA segments. *Biochemical genetics* 45: 623–636.
- Patterson, C., Williams, D. M. and Humphries, C. J., 1993.** Congruence between molecular and morphological phylogenies. *Annual Review of Ecology, Evolution, and Systematics* 24, 153–188.
- Rossi, A. R., Gornung, E. and Crosetti, D., 1997.** Cytogenetic analysis of *Liza ramada* (Pisces, Perciformes) by different staining techniques and fluorescent in situ hybridization. *Heredity* 79, 83–87.
- Rossi, A. R., Capula, M., Crosetti, D., Campton, D. E. and Sola, L., 1998.** Genetic divergence and phylogenetic inferences in five species of Mugilidae (Pisces: Perciformes). *Marine Biology* 131: 213–218.
- Rossi, A. R., Ungaro, A., De Innocentiis, S., Crosetti, D. and Sola, L., 2004.** Phylogenetic analysis of Mediterranean Mugilids by allozymes and 16S mt-rRNA genes investigation: are the Mediterranean species of *Liza* monophyletic? *Biochemical genetics* 42, 301–315.
- Schultz, L.P., 1946.** A revision of the genera of mullets, fishes of the family Mugilidae with description of three new genera. *Proc US Nat Mus* 96: 377–395.
- Semina, A. V., Polyakova, N. E. and Barykov, V. A., 2007.** Analysis of mitochondrial DNA: Taxonomic and phylogenetic relationships in two fish taxa (pisces: Mugilidae and Cyprinidae). WWW.ncbi.nlm.nih.gov/pubmed/18205618.
- Senou, H., Randall, J. F. and Okiyama, M., 1996.** *Chelon*

- persicus*, a new species of mullets (Perciformes: Mugilidae) from the Persian Gulf. *Bull Kansgava Perfecture Museum of Natural Science* 25: 71-78.
- Smith, P. T., Kambhampati, S. and Armstrong, K.A., 2003.** Phylogenetic relationships among *Bactrocera* species (Diptera: Tephritidae) inferred from mitochondrial DNA sequences. *Molecular Phylogenetics and Evolution* 26: 8-17.
- Song, J. K., 1982.** Revision of three common Mugilid fishes from China. *Chin. J. Zool.* 2, 7-12.
- Stiassny, M. L. J., 1993.** What are grey mullets? *Bulletin of Marine Science* 52: 197.
- Tajima, F. and Nei, M., 1984.** Estimation of evolutionary distance between nucleotide sequences. *Molecular Biology and Evolution* 1: 269-285.
- Tajima, F., 1993.** Simple methods for testing molecular clock hypothesis. *Genetics* 135:599-607.
- Thomson, J. M., 1997.** The Mugilidae of the world. *Mem Queensland Mus* 41(3):457-562.
- Thomson, J. M., 1981.** The taxonomy of grey mullets. In Oren OH (ed) *Aquaculture of grey mullets*. Cambridge University Press, Cambridge, pp. 1-16.
- Tortonese, E., 1975.** Fauna de Italia "Osteichthyes". In: *Pesci Ossei*, vol. 11. Calderini, Bologna.
- Trewavas, E. and Ingham, S. E., 1972.** A key to the species of Mugilidae (Pisces) in the northeastern Atlantic and Mediterranean, with explanatory notes. *Journal zoology Landon* 167:15-29.
- Turan, C., Caliskan, M. and Kucuktas, H., 2005.** Phylogenetic relationships of nine mullet species (Mugilidae) in the Mediterranean Sea. *Hydrobiologia* 532,45-51.